

DL3500

User's Guide

Revision 1.01 – March 1, 2004

Table of Contents

Table of Contents	2
1.0 DL3500 General Operation & Applications	3
2.0 Hardware Specifications	4
2.1 Operating Specifications:	4
2.2 Physical Specifications:	4
3.0 DL3500-Hardware Layout	5
4.0 Mode of Operation	6
4.1 Online Mode of Operation	6
4.2 Offline Mode	6
4.3 BIOS Manager Options.....	7
5.0 Switch and LED Indicator Functions	8
5.1 Switch Functions.....	8
5.2 Indicator Functions	8
5.2.1 Power-Up and Reset Sequence.....	8
5.2.2 Normal On-line Operation	8
5.2.3 On-Line, Power-Up and Reset Errors.....	9
5.2.4 Off-Line Modes	9
6.0 DL3500 Wiring Diagrams	10
6.1 Online Cable DL3500-CHA DH+	10
6.2 Online Cable DL3500-CHA DH-485.....	10
6.3 Configuration Cable/Online Cable DL3500-CHB RS-232 – No Handshaking.....	10
6.4 Online Cable DL3500-CHB RS-232C – With Handshaking	10
6.5 Online Cable DL3500-CHB RS-232 – With RTS/CTS Handshaking.....	11
6.6 Online Cable DL3500-CHB RS422/RS485.....	11
7.0 DL3500 DH-485/DH+ Networking Applications	12
7.1 DL3500-Modbus – Modbus Master/Slave to interface to DH-485/DH+.....	12
7.1.1 Modbus Master Mode.....	12
7.1.2 DMX Modbus Master Mode using MODBUS PLUS VIA BM85 BRIDGE.....	13
7.2 DL3500-DF1 – DF1 to DH-485/DH+ interface.....	13
7.3 DL3500-ASCII – DH-485/DH+ to ASCII Scanner/Printer interface.....	14

1.0 DL3500 General Operation & Applications

The DL3500 continues the functionality of the current DL2000/DL3000 product line. It offers both the new addition of DH-485 as well as a plug and play USB interface. As well as having the DH+ and 232/422/485 capabilities of the DL3000. The fully populated DL3500 Model will also allow Bridging between DH+ and DH485 networks in one unit. New is the ability to power the DL3500 from the USB communication link, removing the sometimes cumbersome procedure of location an AC or DC power supply when using laptops or PC's in the field.

The DL3500 has two communication ports. Channel A is designed to connect to you industrial network, either A-B's DH+ or DH-485 networks. Channel B is used to connect to your serial or USB device, the protocol depends on which flavour (model) of the DL3500 you have ordered. Channel B has the capabilities of RS232C, RS422, RS485 and USB.

Configuration of the operating parameters is done quickly and easily by the DL32-3500 windows based software shipped with the unit.

Currently there are three standard DL3500 products available to allow access to A-B's DH-485 and DH+ network. Many other custom ASCII and serial protocols have been implemented to both DH+ and DH-485 on the DL3500 platform. Contact DataLink Technologies Group to see if the DL3500 is the correct device for your communication needs.

The **DL3500** has all three models below available in DH+ and DH-485 flavours:

The **DL3500-Modbus** is a two port device that bridges your Modicon Modbus devices to ones on an A-B DH-485 or DH+ network. The Modbus model can either be used as Modbus Master or Slave as well as having both Modbus ASCII and RTU protocols.

The **DL3500-DF1** is a two port device that allows your DF1 devices (either Full or Half Duplex protocols) to ones on an A-B DH-485 or DH+ network. The DF1 model is a direct replacement for the 1770-KF3 for DH-485 and 1770-KF2 for DH+ and allows your PCs or Laptops access to any node on the corresponding A-B network.

The **DL3500-ASCII** interfaces Serial ASCII devices (Scanners/Printers) to SLC's or other devices on an A-B DH-485 or DH+ network.

2.0 Hardware Specifications

The DL3500 Hardware Platform has the following specifications.

2.1 Operating Specifications:

CHA can be configured for DH-485 at 4800, 9600 or 19.2 Kbaud, as well as DH+ of 57.6, 115.2 and 230.4 Kbaud

CHB has full RS232C, as well as both RS422 4 wire and RS485 2 wire modes. CHB has the ability of being configured with asynchronous speeds upto 230.4 Kbaud as well as the new Plug and Play Windows USB Interface (Version 2.0 implemented on newer models, Please advise DataLink Technology Group if it is important).

Currently DF1, Modbus, and ASCII are the supported protocols. Custom ones are easily implemented. Both CRC 16 and BCC error checking can be implemented; custom error checking can be added at the customer's request.

Simple Parameter Configuration using menu driven Windows (95/98/ME/XP/NT/2000) based Program via RS-232 Cable or USB Interface.

Configuration and Reset Pushbuttons to setup online configuration parameters and do a full Hardware Reset

Operating Parameters are stored in Non-Volatile Serial EEPROM

The DL3500 uses FLASH upgradeable firmware from the configuration Software.

Bi-Color (Green/Red) LED's for each communication channel indicates activity and status. Green POWER LED indicates power on.

2.2 Physical Specifications:

Dimensions: 1.2" H x 4.75" D x 3.2" W (30.4 x 120.7 x 81.3 mm) - Weight 0.56 Lbs (0.2 Kg)

Installation: Metal Enclosure; Desktop, # 8 Bolts, or Din Rail Mounting

Operating Environment: 32 to 122 °F (0 to 50 °C)

Storage: -40 to 185°F (-40 to 85°C)

Humidity: 5% to 95% non-condensing

Power: 9-27V DC or standalone USB - 1.8 Watts

3.0 DL3500-Hardware Layout



This Section contains information of the physical position and purpose of the components of the DL3500.

The top row contains the following connectors. Going left to right.

- 3 pin Power Connector
- CHB/CHC Multipurpose – a CHB DH-485 or RS422/RS485 or CHC RS232 5 pin Screw terminal (Phoenix Type)
- CHA DH+ or DH485 3 pin Screw terminal (Phoenix Type)

The LED's are on the left side going CHA to Power from top to bottom.

The RESET pushbutton is on the left side, the Configure pushbutton is on the right side.

The bottom side of the DL3500 has the following connectors: Going Left to Right.

- Slide Switch for Power selection – USB cable or External DC power
- USB type CHB
- 9 Pin DM9M connector for CHB RS232C communications

4.0 Mode of Operation

4.1 Online Mode of Operation

Online Mode is the normal operating Mode of the DL3500. In this mode the Channels are now configured as they are defined by the configuration and the DL3500 Model. The DL3500 is ready to interface your equipment.

The Reset pushbutton automatically puts the DL3500 into Online mode.

4.2 Offline Mode

Once the Configure Pushbutton is Pressed the Offline BIOS Manager is started. Using either the configuration software and the “**DL Offline Manager**” option or a Windows Hyper Terminal type program with com port settings of 9600 Baud, 8,N,1 and Xon/Xoff flow control.

BIOS MANAGER for DL3500 - Ver 35.01 - Feb 13,03

MAIN MENU

1 - Restore EEPROM to Factory settings

2 - WRITE new Firmware

3 - Memory DUMP

4 - OFF-LINE Diagnostics

5 - DEBUG Mode

6 - FIRMWARE Version

7 - ONLINE

MAKE SELECTION (1-7) –

4.3 BIOS Manager Options

1. Restore EEPROM to factory settings

Once Pressed you will be asked “**Restore EEPROM to defaults (Y/N)?**” If the answer is “Y”es then the Online parameters will be reset to defaults of Address 1, and settings of 9600,N,8,1 on each communication channel.

2. Write New Firmware

Once pressed the message “**This *WILL* overwrite DATALINK system code enter (Y/N) to proceed**” will be displayed. Hit “Y” and the next message will appear telling you that it is alright to send the new firmware to the Flash;

ERASING FLASH, PLEASE WAIT...

SEND FIRMWARE TEXT FILE NOW...

Once the message to send the firmware appears then either click on the “Burn Flash System File” button to select the .txt file to send, or send the Text File under HyperTerminal.

Wait for an “***A-OK* BURN COMPLETE!**” message to appear.

3. Memory Dump

This is used to display the RAM memory of the DL3500. This should only be done after contacting DataLink Technologies Group to debug problems.

4. Off-Line Diagnostics

Starts a series of tests to test the DL3500’s hardware and should only be done if instructed so by a trained person.

5. Debug Mode

Starts up a DL3500 internal Debug mode that can be used by trained personnel to debug problems and check hardware configuration and operation.

6. Firmware Version

Once selected the current DL3500 model and version numbers will be displayed. Can be used to check the correct firmware was burnt into the Flash or if the DL3500 has the most up to date firmware in the Flash.

7. Online

Does a soft “software” reset of the unit to put it online.

5.0 Switch and LED Indicator Functions

5.1 Switch Functions

The Reset pushbutton will perform a complete hardware reset of the DL3500. It is identical to a complete power cycle and will cause the DL3500 to go through its LED start-up sequence as defined in Section 2.3.

The Configure pushbutton takes the DL3500 out of On-Line operation mode and puts it in the BIOS Manager mode. The BIOS Manager mode also allows for configuration parameters to be downloaded from or uploaded to the Windows based configuration software (DL32-3500). When this mode has been entered the CHA and CHC will be RED and CHB will be out. To put the unit back On-line it is necessary to either press the Reset or cycle the DC power supplied to the DL3500.

5.2 Indicator Functions

5.2.1 Power-Up and Reset Sequence

On Power-up or after the Reset button has been pressed the DL3500 executes a self diagnostic check-up of the ram and flash firmware. The correct LED indicator sequence to show the DL3500 is functioning properly is as follows: After all LEDs go out.

LED	STATUS
Power	Green Continuously
CHC	Green for 0.5 seconds
CHB	Green for 0.5 seconds
CHA	Green for 0.5 seconds

After this sequence the DL3500 goes into the On-line mode of Operation. The LED indicators will behave in the certain way defined by the DL3500 model used. Most likely all LEDs will be off waiting for communication on its channels.

5.2.2 Normal On-line Operation

The following is a description of the normal operation of the Channel Leds on the DL3500. Custom products operation will differ than the following:

LED	Description of Operation
Power	Green Indicates Power is being supplied to the DL3500.
CHA, CHB, & CHC	Flashes GREEN for 0.5 seconds when a Character is Received or Transmitted. If Characters are being received or transmitted faster than this then it might appear the LED is on SOLID. Flashes RED for 0.5 seconds if a NAK is received or transmitted in DF1 protocol. Will also flash if all serial communication buffers are full.

5.2.3 On-Line, Power-Up and Reset Errors

The following table describes the meaning of LED patterns if the internal diagnostic tests detect an error on Reset/Power-Up.

LED Pattern	Description of Problem
CHA, CHB, & CHC Flashing RED	The flash has not be burnt properly and the A-OK was not transmitted. Please reburn the flash with the correct text file. Contact Customer Support for help.
CHA, CHB, & CHC Solid RED	The BIOS has been corrupted. A new Flash Chip has to be supplied by the factory. Please contact Customer support.
Start-up Sequence keeps repeating.	The DL3500 EEPROM is corrupt.. Please Restore to Factory Settings (See Section 1.1) and then reconfigure the unit.

5.2.4 Off-Line Modes

The following table describes the meaning of LED patterns in the different Off-Line modes of operation.

LED Pattern	Description of Operation
CHA & CHC Solid RED	BIOS Manager/Configuration Parameter Download/Upload
CHA & CHC Solid Green CHB Solid Red	Offline Hardware Diagnostics Testing Mode
CHA Solid Red CHB & CHC Solid Green	Offline Debug Mode

6.0 DL3500 Wiring Diagrams

6.1 Online Cable DL3500-CHA DH+

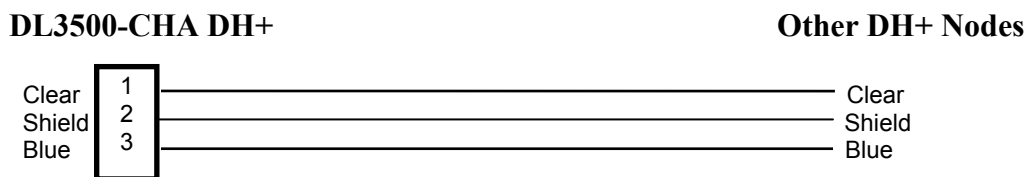

Note: Clear & Blue might have to be swapped depending on existing DH+ wiring

6.2 Online Cable DL3500-CHA DH-485

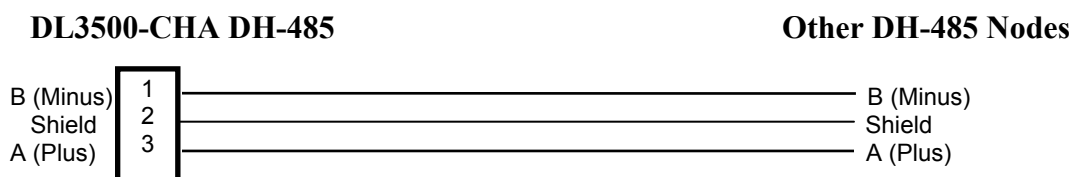

6.3 Configuration Cable/Online Cable DL3500-CHB RS-232 – No Handshaking

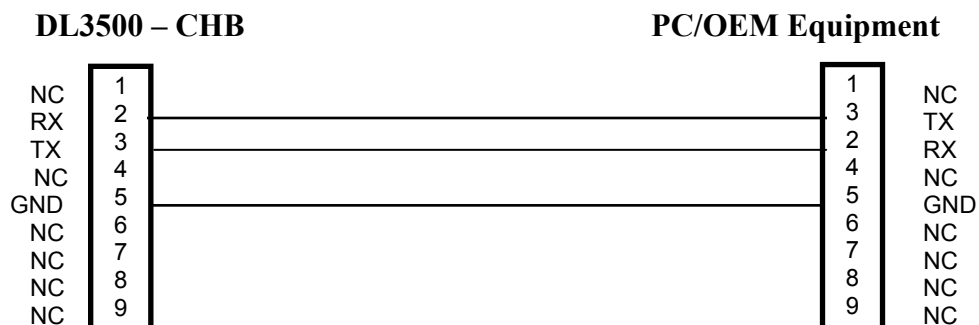

6.4 Online Cable DL3500-CHB RS-232C – With Handshaking

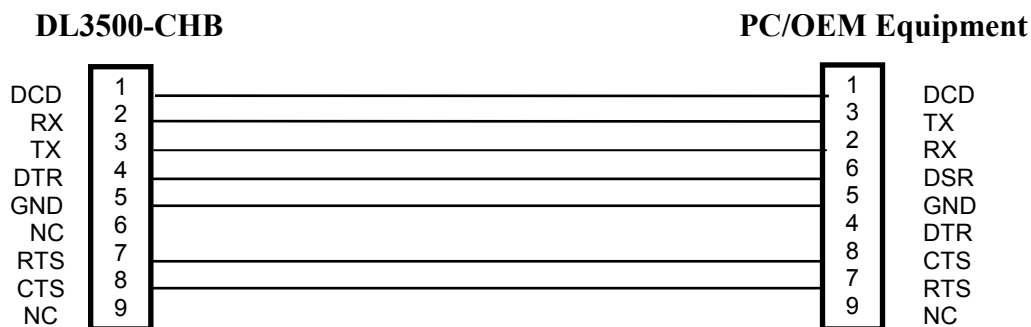

6.5 Online Cable DL3500-CHB RS-232 – With RTS/CTS Handshaking

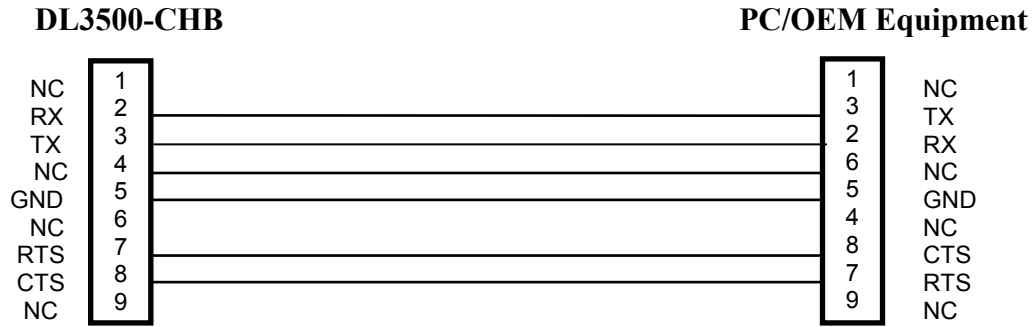

6.6 Online Cable DL3500-CHB RS422/RS485

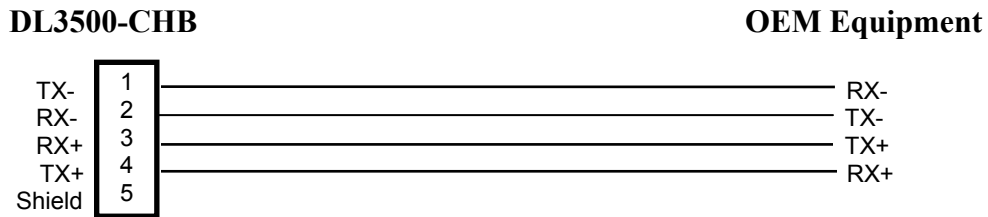

Note: 5 Pin Connectors are numbered from Left to Right
 For two wire RS485 Jumper Pins 1-2 and 3-4 for - and + wires respectively

7.0 DL3500 DH-485/DH+ Networking Applications

7.1 DL3500-Modbus – Modbus Master/Slave to interface to DH-485/DH+

7.1.1 Modbus Master Mode

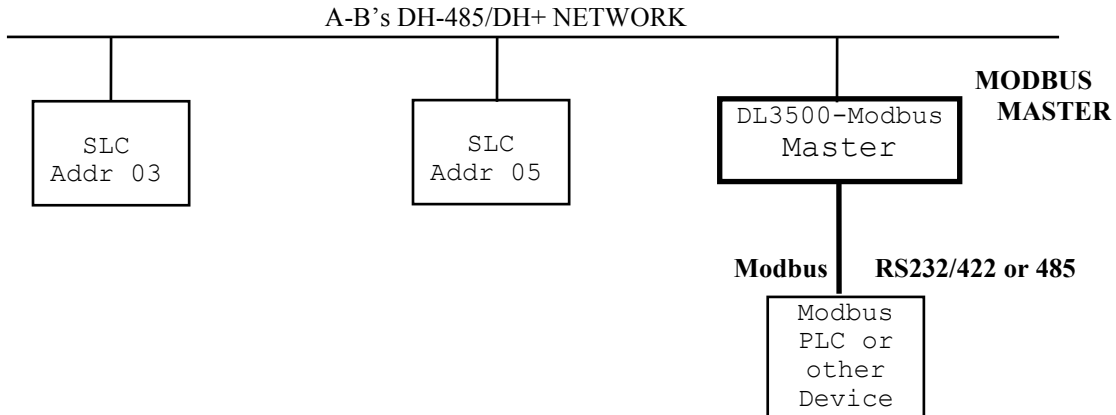

NOTE:

The Modbus Master can communicate with any Slave device on the Modbus Slave network and any DH-485/DH+ devices capable of sending PLC5 message commands. Modbus and DH-485/DH+ addresses must not be duplicated (convert to the same radix) or the Master will receive two responses. The DL3500 can be any station number on DH-485/DH+ including Station 00 (not used on Modbus).

7.1.2 DMX Modbus Master Mode using MODBUS PLUS VIA BM85 BRIDGE

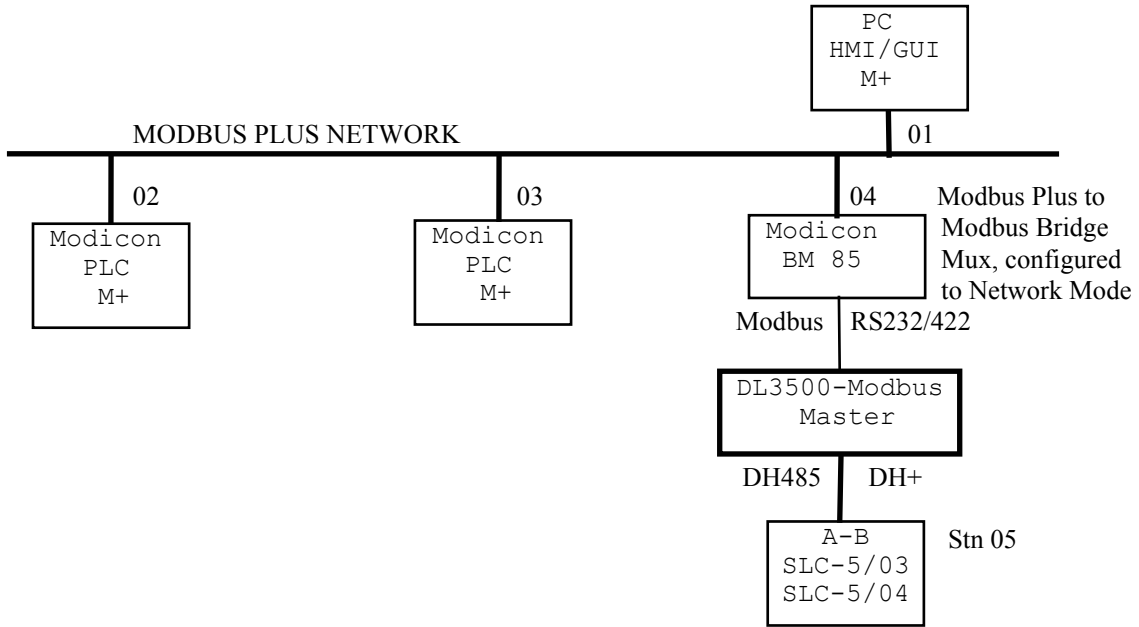

NOTE:

PLCs and HMIs etc. on Modbus Plus can be programmed to communicate with PLC5s, SLC5/04s and HMIs on DH-485/DH+, i.e. any devices capable of handling PLC-5 Type message commands.

7.2 DL3500-DF1 – DF1 to DH-485/DH+ interface

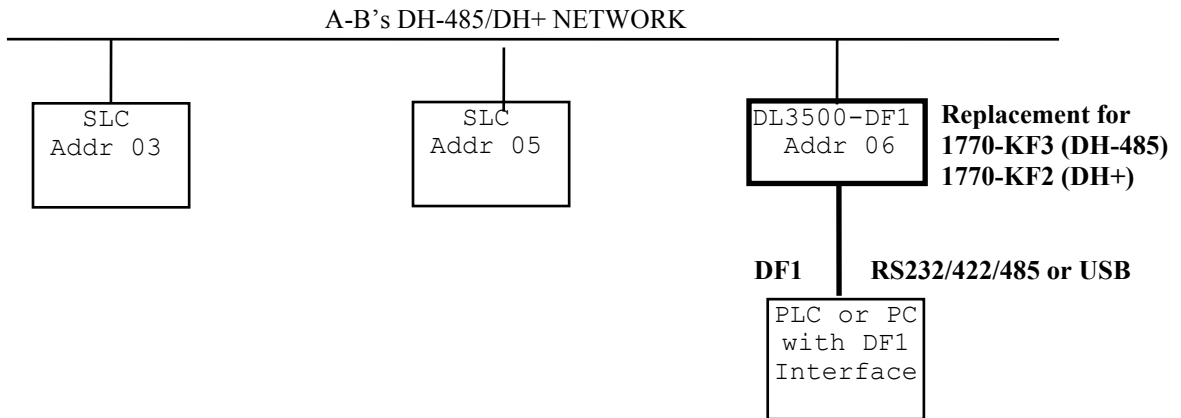

Note:

PC can be running RS-LINX or like software (MMI) to have access to nodes on the DH-485/DH+ Network. Modbus RTU Network could also be RS232.

7.3 DL3500-ASCII – DH-485/DH+ to ASCII Scanner/Printer interface

